

| Model | A | B | C | D | Ø glass hole | Thickness wall/glass |
|------------------------------|-----|-----|-----|----|--------------|----------------------|
| SMART 15/6 A-M | 215 | 215 | 100 | 30 | 184+195 | 3+20 |
| SMART 23/9 M-AR-Silent-Wi fi | 321 | 331 | 141 | 30 | 254+262 | 3+50 |
| SMART 30/12 AR-Silent-Wi fi | 375 | 385 | 148 | 30 | 324+337 | 3+50 |

SMART

AXIAL FAN GLASS MOUNTING

- Axial fans to extract air directly outside;
- Glass, double glass, wall or panel mounting up to 50mm;
- Smart gaskets to prevent vibration and water ingress;
- Ball bearing motor (except 15/6 M-A, 23/9 and 30/12 Silent version);
- Double insulated product, without ground wire for fast connection;
- Optional kit for wall and double glass installation;
- Operating indicator light;
- On/Off, reversible airflow (extraction/intake) and 5 speed through optional RG 5 AR controller;

- Rain proof IPX4 external grille;
- Body and grilles in white ABS;
- Integrated internal automatic shutter prevents ingress of air from outside while turned off;
- Versions: M (manual), A (automatic), AR (automatic and reversible), Wall (built in installation);
- Wi-Fi version provided with remote radio control;
- In accordance with Standard EN 60335-2-8.



POSITIONING

- Wall mounting - Glass mounting

TECHNICAL DATA

| Model | Code | Ø hole (mm) | Voltage (V) | Frequency (Hz) | Flow rate (m³/h) | Max press. (mm H ₂ O) | Max press. (Pa) | Power (W) | Noisiness dB(A) _{3m} | Weight (Kg) |
|-----------------------|---------|-------------|-------------|----------------|------------------|----------------------------------|-----------------|-----------|-------------------------------|-------------|
| SMART 15/6 M | 0072800 | 184-195 | 220-240 | 50 Hz | 230 | 5,1 | 50 | 29 | 40 | 1,3 |
| SMART 15/6 A | 0072700 | 184-195 | 220-240 | 50 Hz | 230 | 5,1 | 50 | 29 | 40 | 1,3 |
| SMART 23/9 M | 0072100 | 254-262 | 220-240 | 50/60 Hz | 750 | 6,6 | 65 | 40 | 43 | 3,7 |
| SMART 23/9 AR | 0072000 | 254-262 | 220-240 | 50/60 Hz | 750 | 6,6 | 65 | 40 | 43 | 3,7 |
| SMART 23/9 AR Wall | 0072600 | 254-262 | 220-240 | 50/60 Hz | 750 | 6,6 | 65 | 40 | 41 | 3,7 |
| SMART 23/9 AR Wi Fi | 0071600 | 254-262 | 220-240 | 50/60 Hz | 750 | 6,6 | 65 | 40 | 43 | 3,7 |
| SMART 23/9 AR Silent | 0072500 | 254-262 | 220-240 | 50/60 Hz | 500 | 2,5 | 25 | 30 | 33 | 3,7 |
| SMART 30/12 AR | 0071400 | 324-337 | 220-240 | 50/60 Hz | 1400 | 8,2 | 80 | 60 | 46 | 6,1 |
| SMART 30/12 AR Wi Fi | 0071800 | 324-337 | 220-240 | 50/60 Hz | 1400 | 8,2 | 80 | 60 | 46 | 6,1 |
| SMART 30/12 AR Silent | 0071300 | 324-337 | 220-240 | 50/60 Hz | 1000 | 5,1 | 50 | 45 | 39 | 5,6 |

FURTHER INFORMATION

SMART 23/9 AND 30/12

- Easy and quick installation on glass through a special fixing system by click springs and final screw blocking
- The front grille can be easily removed by loosening the two safety screw and pressing both fan sides.

Flow rate m³/h (with RG5 AR controller)

| Model | I° Speed | II° Speed | III° Speed | IV° Speed | V° Speed |
|-----------------------|----------|-----------|------------|-----------|----------|
| Smart 23/9 AR Silent | 200 | 250 | 350 | 420 | 500 |
| Smart 23/9 M-AR-Wall | 280 | 370 | 510 | 640 | 750 |
| Smart 30/12 AR Silent | 400 | 500 | 650 | 820 | 1000 |
| Smart 30/12 AR | 600 | 840 | 1050 | 1200 | 1400 |

SMART 15/6

- Easy and fast installation on glass through two fixing screws with an original clicking and plugin system. No screws required to block the connection cable.

QUOTE FOR GLASS INSTALLATION

- The large tolerance on the diameter hole in the glass allows to recover some imprecisions or even to adapt the fan to any existing hole. All SMART versions are suitable for single, double glass, glass or wood panel.

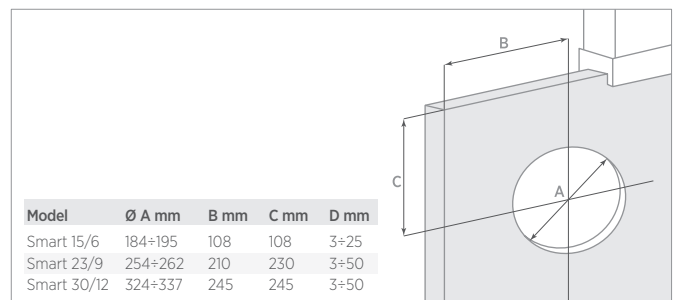

| Model | Ø A mm | B mm | C mm | D mm |
|-------------|---------|------|------|------|
| Smart 15/6 | 184+195 | 108 | 108 | 3+25 |
| Smart 23/9 | 254+262 | 210 | 230 | 3+50 |
| Smart 30/12 | 324+337 | 245 | 245 | 3+50 |

flow rate m³/h (with RG5 controller)

| Model | I° Speed | II° Speed | III° Speed | IV° Speed | V° Speed |
|----------------|----------|-----------|------------|-----------|----------|
| Smart 15/6 M-A | 75 | 95 | 145 | 195 | 230 |

SMART WI-FI

The fan, operated by a wireless remote radio control, simply requires the connection to the electric system (L-N). The provided remote radio control (supplied with 12V battery) runs all product's functions (on-off, reversibility and 3 speed within a maximum range of 30 meters). Being a radio remote

control, it is not necessary to point it directly towards the fan and can be installed on wall or panel by two fixing screws. The polished design of the Wi-Fi radio transmitter perfectly integrates with the other elements of the electric installation.

FLOW CHARTS

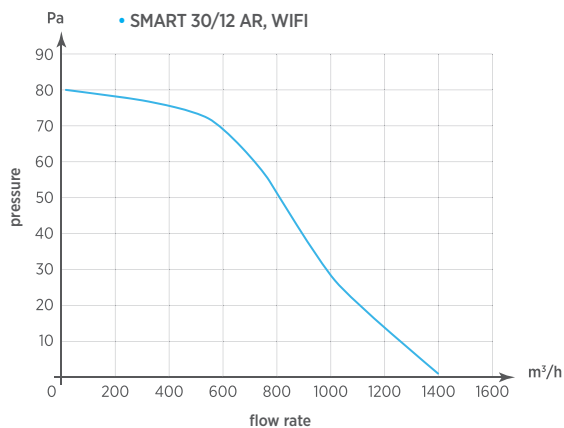
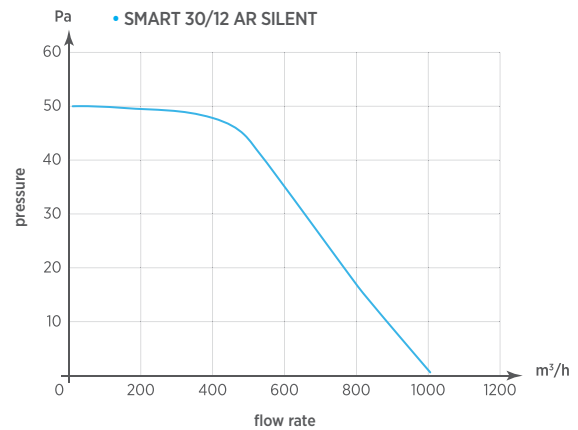
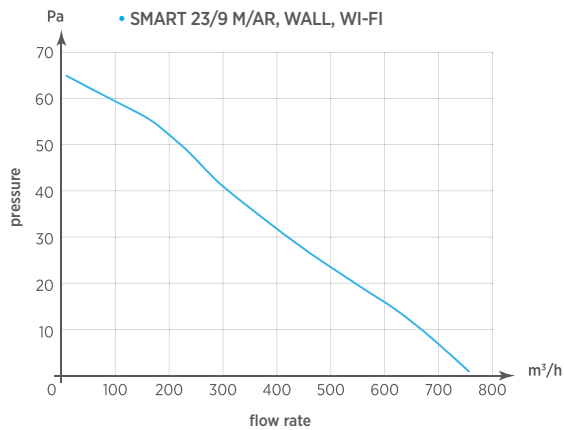
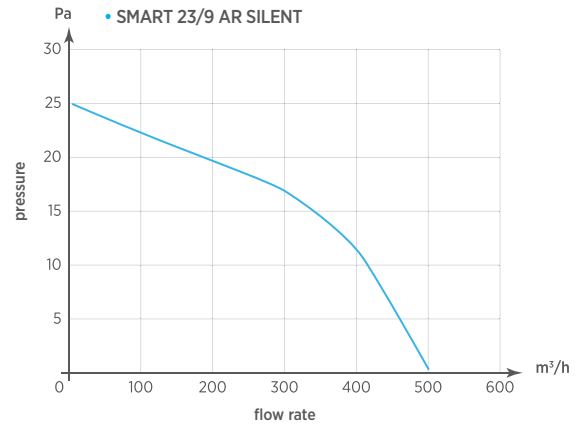
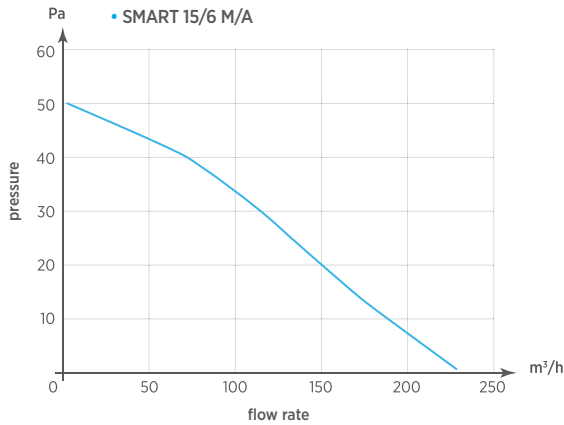

ACCESSORIES:
SEE PAGE 56



Double glass kit

Fixing wall kit

Controller